



# Newsletter

www.espcorp.com

Volume 2, Issue 1

## FEATURE

### Don't Get Boxed In...

**Boxed forms** slowing you down? Concerned with lost productivity in your print facility? ESP always has a solution.

*Webtrend Direct*, a full-service, California-based production

company consulted ESP for a customized solution to increase production at their laser print facility. Initially, Webtrend ran six Océ Pagestream printers, with no pre or post processing equipment. Running their printers in a "box-in, box-out" format required that the printers be stopped and started repeatedly. "Our concern," said Brad Pollard, Vice-President of Webtrend, "was the loss of productivity and the additional wear and tear resulting on our printers."

**To automate their production, the "first step,"** Brad told us, "was to add

**THE TRUTH:**

Running roll stock has advantages, but many print shops still handle numerous boxed forms jobs.

**THE GOOD NEWS:**

Splicing your forms on a box feeder, such as the ESP460 Box Feeder/ Splicer can give you up to 27% more production!

ESP460 Box Feeder/Splicers to our Océ printers." The ESP Box Feeder solution allowed Webtrend to splice multiple stacks of forms to be ready to print. The solution also made it easier

for operators to work on multiple printers simultaneously. "The ESP Box Feeder/Splicer was a great and inexpensive way to begin automating our print environment," said Brad.

**With their high volumes of production and tight deadlines,** Webtrend wanted even more automation, and ESP had the solution: adding several ESP Roll Unwind Processors to their printers. Now Webtrend takes advantage of using jumbo continuous form rolls to increase productivity.

**Finally, with the input end of the print process automated,** Webtrend and ESP tackled the output end. ESP's post-processing answer? An ESP726 Continuous Forms Cutter to feed an existing MBO folder, taking full advantage of their printer's capabilities. This addition reduced Webtrend's production process to two steps: Print-Cut-Fold and Insertion. "With a Cut-to-Fold solution on the back end of the printer, you start seeing what the benefits of running roll stock are," Brad comments.

**Webtrend uses a number of different paper stocks** including matte and coated stocks. These heavier types of paper tend to cause fold errors in the printer's stacker. "By running rolls on the ESP Unwinder or splicing [boxed

forms]," Brad told us, "you can straighten the paper path...with the addition of a finishing line, you can eliminate the stacker, where most of the folding problems occur."

**"We now produce more product per hour using ESP's solution,** which has increased our bottom line." Converting to roll stock and automating post-processing, he says, created obvious productivity gains.

**Brad also mentioned that reaching their increased productivity goals with ESP's help** also gave Webtrend more print capacity. "By providing complete print processing solutions," he says, "ESP helped us realize our highest printer productivity, giving us a maximum return on our equipment investment."

*Brad Pollard and Mark Robinson with the ESP460 in Webtrend's print room.*



**Webtrend Direct**  
1811 Riverview Drive  
San Bernardino, CA 92408  
Brad Pollard  
Phone: 909-799-5435  
Fax: 909-799-5449  
www.webtrend.com

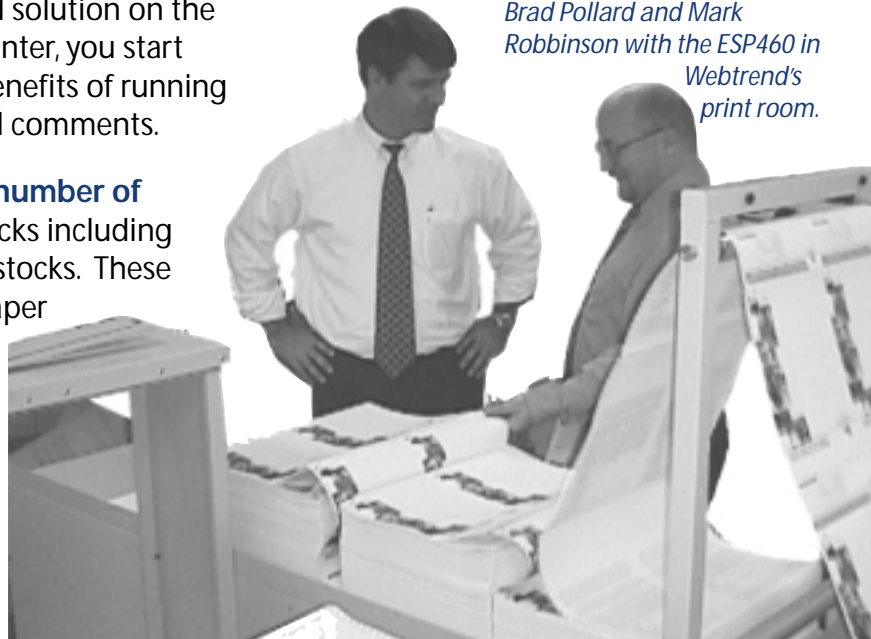



## contents

Volume 2, Issue 1  
February 2000

### FEATURE:

### DEPARTMENTS

*Business*

**Q & A:** Pricing  
Equipment Leasing

*Solutions*

Solution Sets

*Shows & Events:*

OnDemand 2000



## letters

### Comments? Questions?

We'd love to hear from you....

### MAIL

Energy Saving Products  
Julie Howard, Editor  
c/o ESP Newsletter  
713 George Washington Tpke  
Burlington, CT 06013-2037

### FAX

(860) 675-1579

### E-MAIL

espnews@espcorp.com  
www.espcorp.com

Please include your name and address on all correspondence.

# Q.

How can ESP offer equipment at such affordable prices? Is the material quality comparable to other manufacturers?

# A.

## BUSINESS

Our machines are not built cheaper, they are built smarter. ESP uses only the highest quality materials and parts to build our equipment.

By using automated production procedures, we have reduced production time **and** production costs. And we pass the savings along to our customers.

Not only that, but we price our machines based on cost plus profit, NOT what the market will bear. With 10 years of experience in the industry, we at ESP can confidently say that our growth is due to the quality of products and services we offer.

\* Do **you** have a question for our Q&A section? Send it to us at [espnews@espcorp.com](mailto:espnews@espcorp.com). If it is relevant to the industry, we will publish it here with the answer!

## LEASING--MORE THAN JUST A TREND

With 80% of US companies currently leasing some or all of their equipment, leasing is an option with staying power. Businesses on the way up are always concerned about protecting their capital. Leasing gives growing companies the ability to sidestep financial obstacles such as: huge down payments, monthly finance charges and dwindling credit lines.

As the folks at **U.S. Commerce Equipment Finance** say: "Ownership of equipment alone will not produce revenue. It is the use of equipment which is productive. When viewed from this perspective, leasing is frequently less expensive."

Some key benefits leasing brings to companies are:



Looking for the absolute best deal on Pre & Post Equipment? Make ESP your last stop.

Call today for details on special demo pricing!  
(860) 675-6443

- \* 100% financing--amount of cash up-front is reduced.
- \* Credit line remains free for other purchases in which leasing is NOT an option.
- \* Simplified accounting and easier financial management.
- \* Maximized tax benefits and protection from inflation.
- \* Flexibility--leasing helps your company meet financial objectives with options such as fixed rate financing and a variety of payment options including deferred payments, skip payments, cyclical payments, among others\*\*.
- Leasing equipment is a great way for your company to maximize potential, helping you grow your company without the financial restrictions typical in other forms of capital purchases.

*Thank you to U.S. Commerce Equipment Finance, L.L.C. for their help and information.*

\*\*Not all these payment options are available through all leasing companies. You will need to inquire which are available before you sign an agreement.

ESP  
Offers  
Equipment  
Leasing  
Options!!  
Call us  
Today!

# DOCUMENT PROCESSING

## TECHNOLOGY

# SOLUTION SETS THAT SAVE!

## SOLUTIONS

### Box to Fold

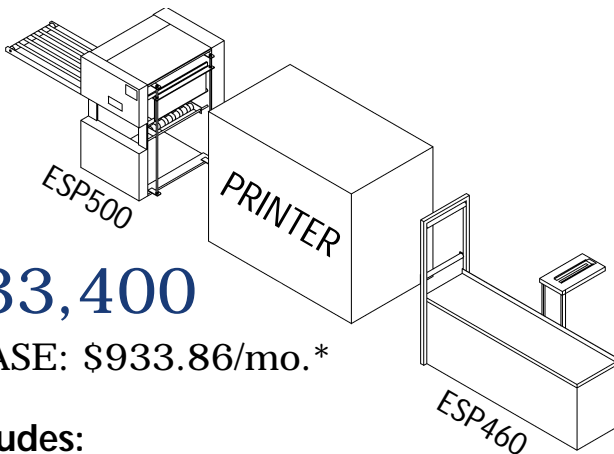

**\$33,400**

LEASE: \$933.86/mo.\*

**Includes:**

ESP500 Forms Fold Processor  
ESP460 Box Feeder  
ESP Printer Interface

**Automate your Printer TODAY!**

ESP solutions are compatible with:

IBM Printing Systems

OCÉ Printing Systems

Xeikon/NIPSON

and other continuous feed printers

### Roll to Roll

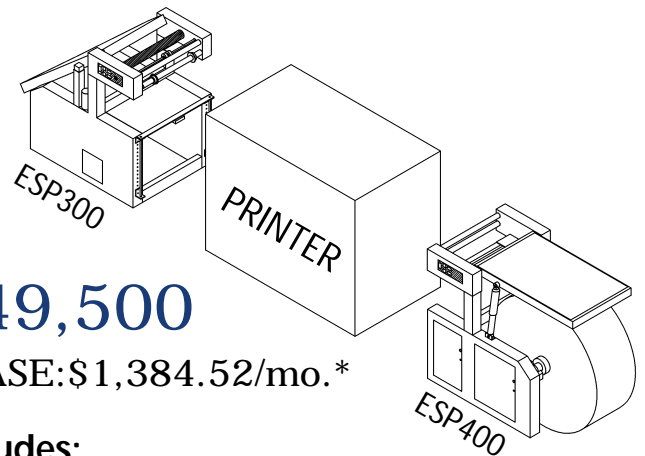

**\$49,500**

LEASE: \$1,384.52/mo.\*

**Includes:**

ESP300 Roll Rewind Processor  
ESP400 Roll Unwind Processor  
ESP12 Roll Lift/Transport Cart  
ESP Printer Interface  
2 - ESP Roll Core Shafts

### Box to Cut

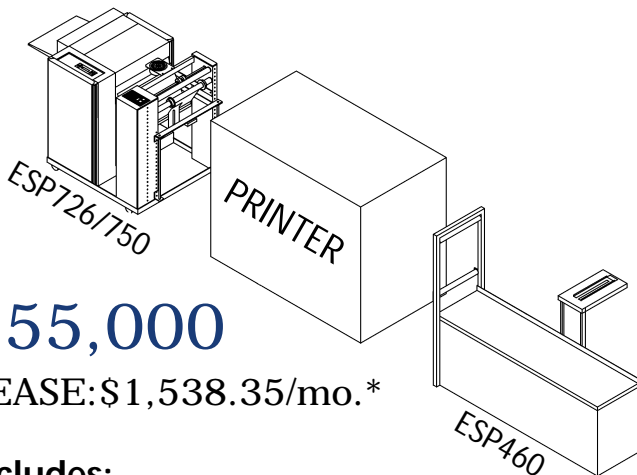

**\$55,000**

LEASE: \$1,538.35/mo.\*

**Includes:**

ESP460 Box Feeder  
ESP726 Continuous Forms Cutter  
ESP750 Descending Stacker  
ESP Printer Interface

## Tips that Save you Money!

1. Using ESP460 box feeders offline in your finishing department can save you up to 30% in production time when compared to running pre AND post on your printer! Just \$2000 to automate your offline production with the ESP460!
2. Roll-to-Roll provides maximum unattended print operation!
3. Buy complete systems! Take advantage of special offers, like the solutions above!

\* Pricing applies to equipment bought directly through ESP.  
Pricing does not apply to dealers.

\*Lease Terms:

48 Months. No money down. No payment due for 90 days.

## Shows/Events

**WHO:** ESP

**WHAT:** *OnDemand Expo 2000*

**WHEN:** February 29 - March 2

**WHERE:** Jacob Javits Center, NY

**BOOTH # 2939**

**Need a pass to the  
show?**

**Call us!**

**860-675-6443**



**Once Again,** ESP  
and Océ bring you a  
treat!

Watch ESP's Roll-to-Cut/Stack/Separate solution on an Océ duplex-printing set up.

Also, we will demonstrate offline finishing with Inkjet and accumulation technologies.



Here's your chance to see Roll-Feed technologies at work in ESP's booth **AND** take home the **THIRD** volume of the ESP cookbook, this time devoted to

*"Just Desserts!"*

**Enjoy!**

.....  
**Sales:** 888-237-7462; [sales@espcorp.com](mailto:sales@espcorp.com)  
**Technical Support:** 860-675-6443; [techsupport@espcorp.com](mailto:techsupport@espcorp.com)  
**ESP Newsletter:** [espnews@espcorp.com](mailto:espnews@espcorp.com)  
**ESP On-Line:** [www.espcorp.com](http://www.espcorp.com)

PRST STD  
MAIL (A)  
Postage Paid  
Permit #1108  
Hartford, CT

Newsletter

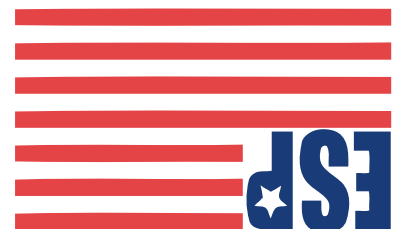

Energy Saving Products  
713 George Washington Tpk  
Burlington, CT 06013-2037